



1	2	3	4	5	6	7	8	9	10	
A	APPARATSKÅP SEE COOLING (EBMPAPST)									
B	INNEHÅLLSFÖRTECKNING 1									
C	APPARATPLACERING 2									
D	APPARATLISTA 3									
E	HUVUDKRETSSCHEMA 4									
F	MANÖVERKRETSSCHEMA 5 - 7									
G	YTTRE ANSLUTNINGSSCHEMA 8 - 12									
H	 <b>AVS</b> ELKRAFT & AUTOMATION TEL +46(0) 472 162 00 WWW.AVS-AB.COM									
 <b>AIA</b> <b>Cooling Your Daily Life®</b> <small>Member of LU-VE GROUP</small>										
<b>LU-VE SWEDEN AB</b> TEL +46(0) 454 334 00 <b>WWW.AIA.SE</b>					<b>30329382</b> HDZ3-6-33-42-X/P-R30-2W SEE COOLER INNEHÅLLSFÖRTECKNING					
ARBETSNUMMER KONSTRUERAD AV MKW DATUM 2021-09-10					RITTINGSNUMMER <b>614-7143924</b> RITAD AV MKW REV. FORTS. 2					
REV.	ÄNDRING	SIGN.	DATUM							



DIN SKENA 330mm

X1

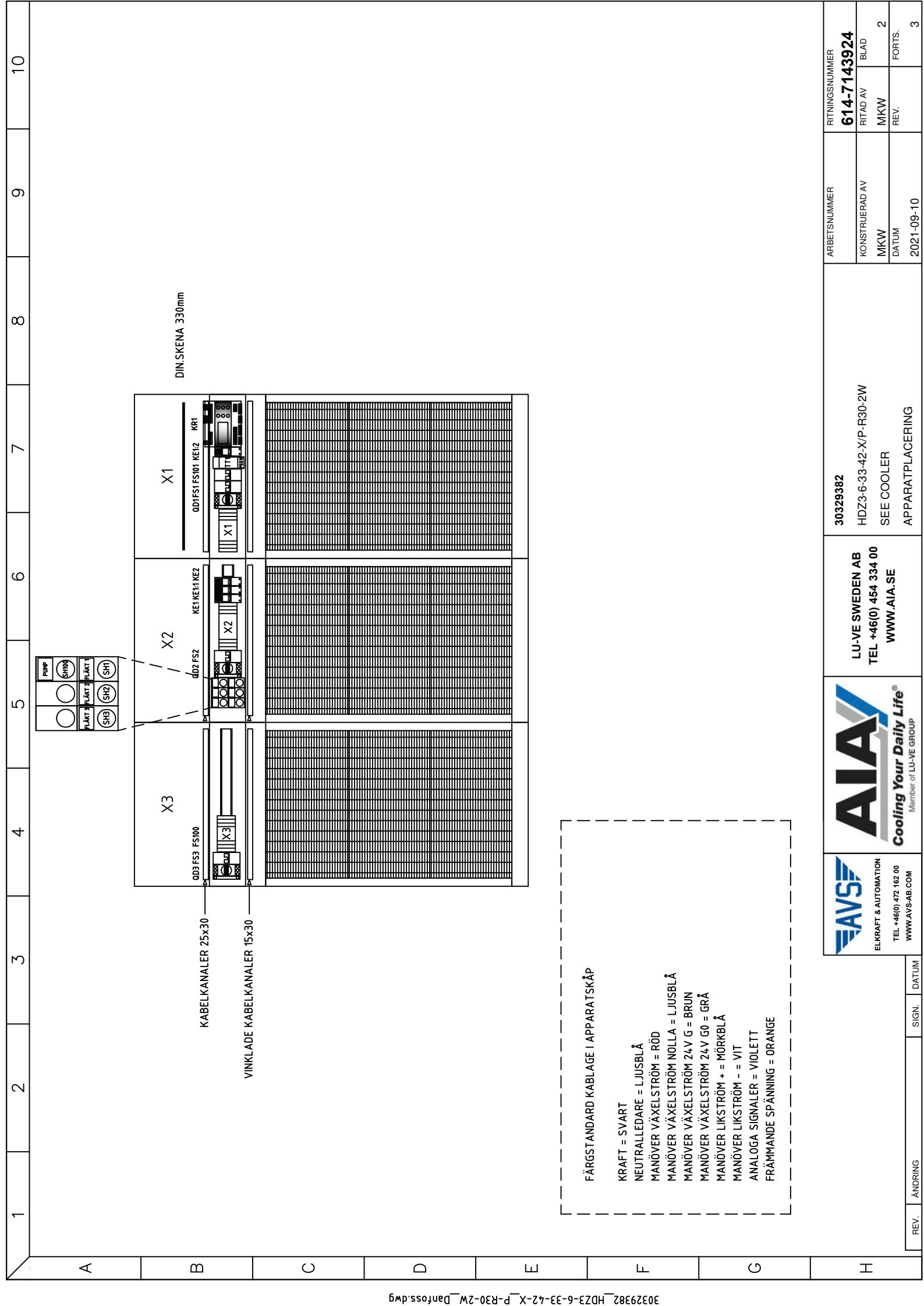
X2

X3



KABELKANALER 25x30



VINKLADE KABELKANALER 15x30

RÖD	○	○	○
LUSBLÅ	○	○	○
MÖRKBLÅ	○	○	○
VIT	○	○	○

FÄRGSTANDARD KABLAGE I APPARATSKÅP

KRAFT = SVART  
 NEUTRALLEDARE = LJUSBLÅ  
 MANÖVER VÄXELSTRÖM = RÖD  
 MANÖVER VÄXELSTRÖM NOLLA = LJUSBLÅ  
 MANÖVER VÄXELSTRÖM 24V G = BRUN  
 MANÖVER VÄXELSTRÖM 24V G0 = GRÅ  
 MANÖVER LIKSSTRÖM + = MÖRKBLÅ  
 MANÖVER LIKSSTRÖM - = VIT  
 ANALOGA SIGNALER = VIOLETT  
 FRÄMMANDE SPÄNNING = ORANGE

RITTINGSNUMMER	614-7143924		
	RITAD AV	MKW	2
ARBETSNUMMER	30329382		
	KONSTRUERAD AV	MKW	2
DATUM	2021-09-10		
	APPARATPLACERING	SEE COOLER	
 ELKRAFT & AUTOMATION TEL +46(0) 472 162 00 WWW.AVS-AB.COM			
 Cooling Your Daily Life® Member of LU-VE GROUP			
LU-VE SWEDEN AB TEL +46(0) 454 334 00 WWW.AIA.SE			
HDZ3-6-33-42-X/P-R30-2W APPARATPLACERING			
REV.	ÄNDRING	SIGN.	DATUM

1	2	3	4	5	6	7	8	9	10	
A	POS	ANTAL	NAMN	TILLVERKARE	TYP	DATA	ART-NUMMER	ANMÄRKNING		
		3	MONTERINGSPLÅT	AVS	BAS-PLÅT		602-1009910			
		1	MONTERINGSPLÅT	AVS	PLÅT REGULATOR		602-1009911			
		1	MONTERINGSPLÅT	AVS	PLÅT BRYTARE		602-1009912			
B	QD1-QD3	3	HUVUDBRYTARE	SONTHEIMER	HLO40/4T/Z20Bggf	4-POLER	131-3134270			
	FS1-FS3	3	DVÄRGBRYTARE	SCHNEIDER ELECTRIC	A9F07206	iC60H 2P C6A	121-2112149			
	FS101	1	DVÄRGBRYTARE	SCHNEIDER ELECTRIC	A9F07206	iC60H 2P C6A	121-2112149			
	FS100	1	PLINTSÄKRING	WEIDMULLER	WSI 6	0.5A	129-2919864			
	(FS100)	1	ÄNDPLATT	WEIDMULLER	WAP 2,5-10		129-2919921			
C	SH1-SH3	3	BRYTARE	SCHNEIDER ELECTRIC	XB4BD33	3-FAST POSITIONER/2NO	137-3732626			
	SH1-SH3	3	HJÄLKONTAKT	SCHNEIDER ELECTRIC	ZBE101	NO	137-3733195			
	SH1-SH3	3	SKYLTHÅLLARE	SCHNEIDER ELECTRIC	ZBZ33	18X27	137-3733523			
	SH100	1	BRYTARE	SCHNEIDER ELECTRIC	XB4BD21	2-FASTA POSITIONER/NO	137-3732624			
	SH100	1	HJÄLPKONTAKT	SCHNEIDER ELECTRIC	ZBE101	NO	137-3733195			
	SH100	1	SKYLTHÅLLARE	SCHNEIDER ELECTRIC	ZBZ33	18X27	137-3733523			
D	KE1-KE12	3	RELÄ	SCHNEIDER ELECTRIC	RXM4AB2P7	4-POLER 230VAC	140-4027797			
	KE2	1	RELÄ	SCHNEIDER ELECTRIC	RXM4AB2B7	4-POLER 24VAC	140-4027794	BLADFÄDER		
	KE1-KE2	4	RELÄ SOCKEL	SCHNEIDER ELECTRIC	RXZE14P	4-POLER	140-4099132			
	TT1	1	TRANSFORMATOR	TUFVASSONS	PSS10	230/24VAC 10VA	152-5204035	PTC SKYDD		
E	KR1	1	REGULATOR	DANFOSS	MCX08M2	230VAC	145-9945239			
	X1	33	PLINT	WEIDMULLER	A3C 15	BLADFÄDER	129-2919334			
	X1	2	JORDPLINT	WEIDMULLER	A3C 2,5 PE	BLADFÄDER	129-2919118			
	X1	1	ÄNDPLATT	WEIDMULLER	A3C 2,5		129-2919234			
	X2	20	PLINT	WEIDMULLER	A3C 2,5	BLADFÄDER	129-2920113			
	X2	2	JORDPLINT	WEIDMULLER	A3C 2,5 PE	BLADFÄDER	129-2919118			
	X2	1	ÄNDPLATT	WEIDMULLER	A3C 2,5		129-2919234			
F	X3	9	PLINT	WEIDMULLER	PDU2,5/3	BLADFÄDER	129-2920113			
	X3	2	JORDPLINT	WEIDMULLER	A3C 2,5 PE	BLADFÄDER	129-2919118			
	X3	1	ÄNDPLATT	WEIDMULLER	A3C 2,5		129-2919234			
	X1/X2/X3	5	ÄNDSTÖD	WEIDMULLER	ZEW35		129-2919930			
G	W	42	KABELMÄRKNING	WEIDMULLER	1852360000	GUL	614-7140000			
		3	EMBALLAGE	HELMER NILSSON	WELLOMSLAG 0409		380-0000094			
H	REV.	ÄNDRING	SIGN.	DATUM	 ELKRAFT & AUTOMATION TEL +46(0) 472 162 00 WWW.AVS-AB.COM		 AIA Cooling Your Daily Life Member of LU-VE GROUP		ARBETSNUMMER <b>30329382</b>	RITINGSNUMMER <b>614-7143924</b>
					LU-VE SWEDEN AB TEL +46(0) 454 334 00 <b>WWW.AIA.SE</b>		KONSTRUERAD AV <b>MKW</b>	RITAD AV <b>MKW</b>	FORTS. <b>3</b>	
					SEE COOLER APPARATLISTA		DATUM <b>2021-09-10</b>	REV. 	FORTS. <b>4</b>	

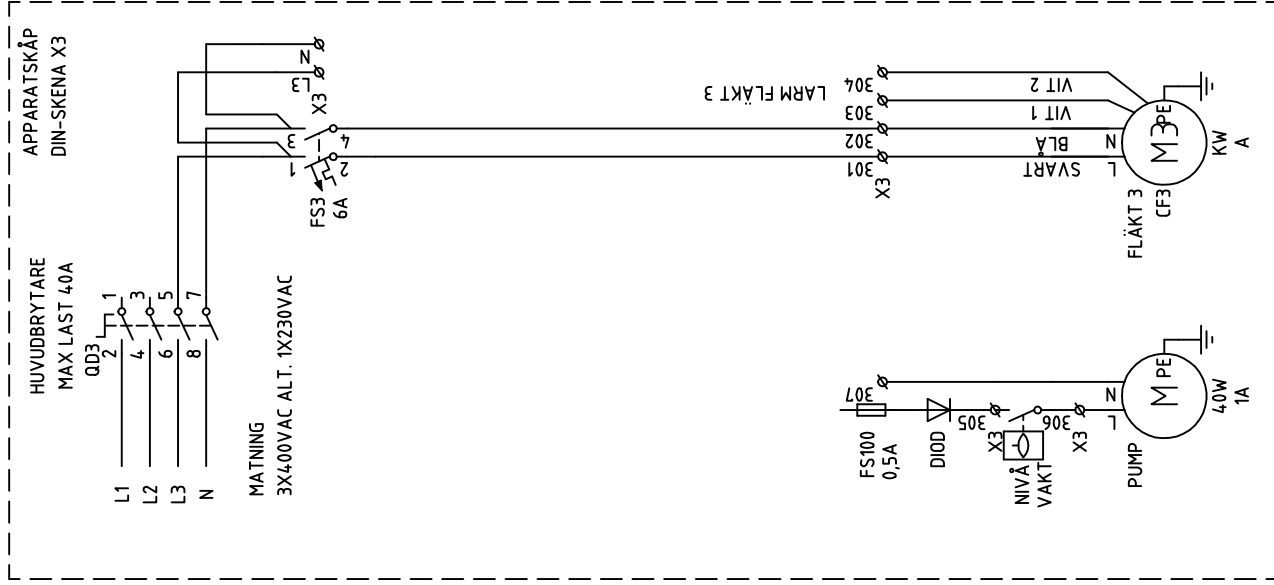
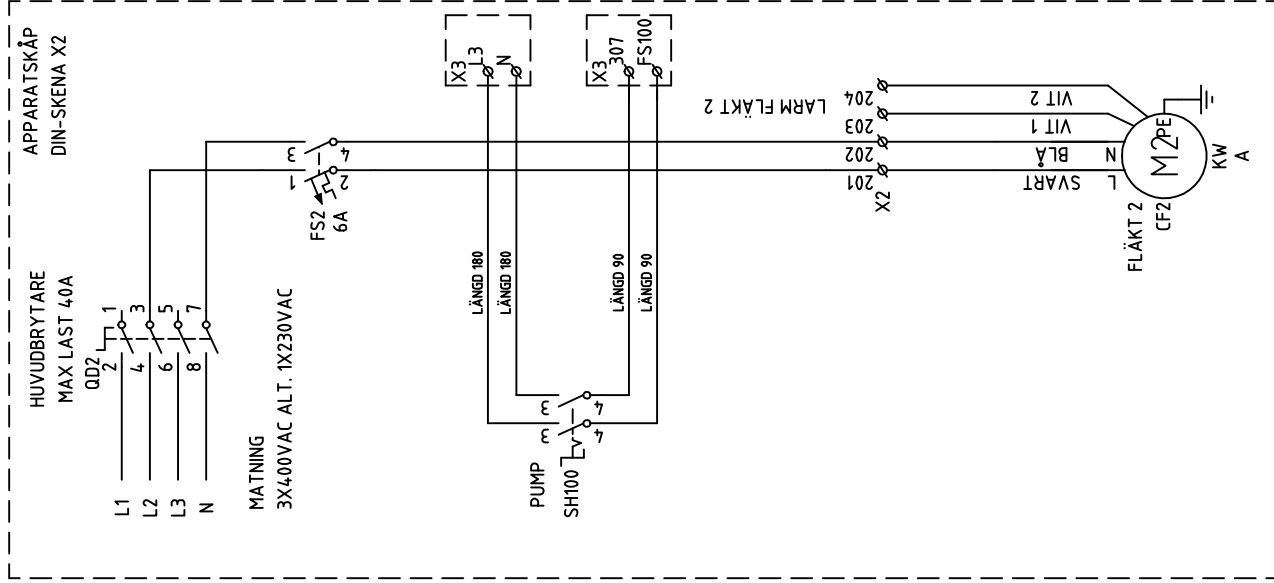
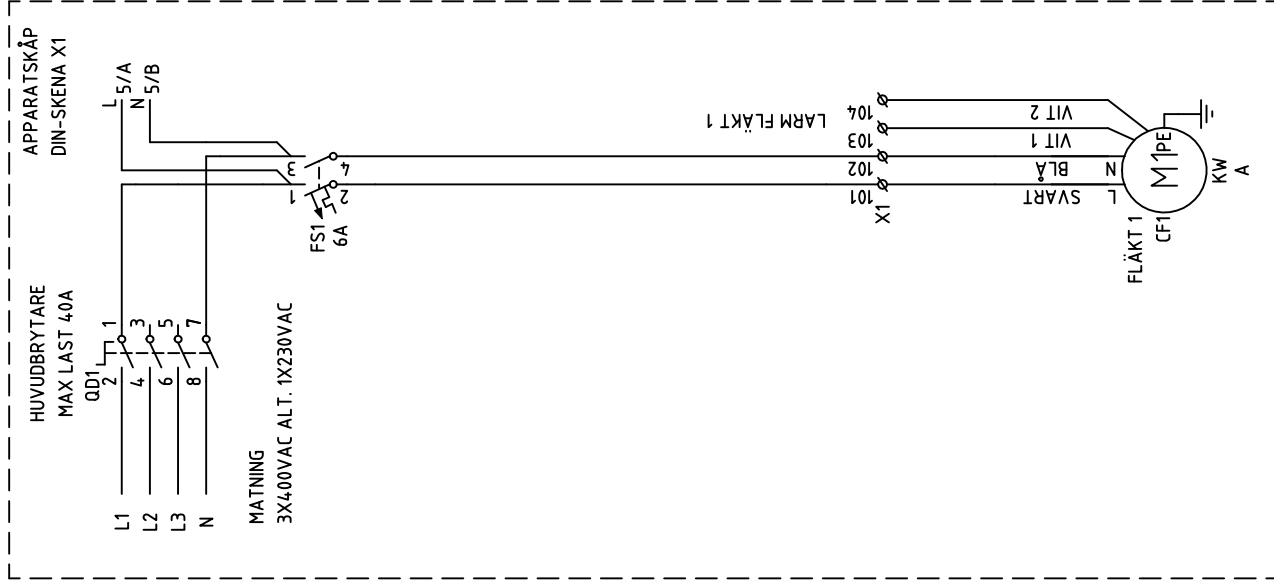

LU-VE SWEDEN AB  
TEL +46(0) 454 334 00  
WWW.AIA.SE

30329382  
HDZ3-6-33-42-X/P-R30-2W  
SEE COOLER  
HUVUDKRETSSCHEMA

ARBETSNUMMER	614-7143924
KONSTRUERAD AV	MKW
DATUM	2021-09-10
REV.	4
FORTS.	5

RITINGSNUMMER	614-7143924
BLAD	4
REV.	4
FORTS.	5



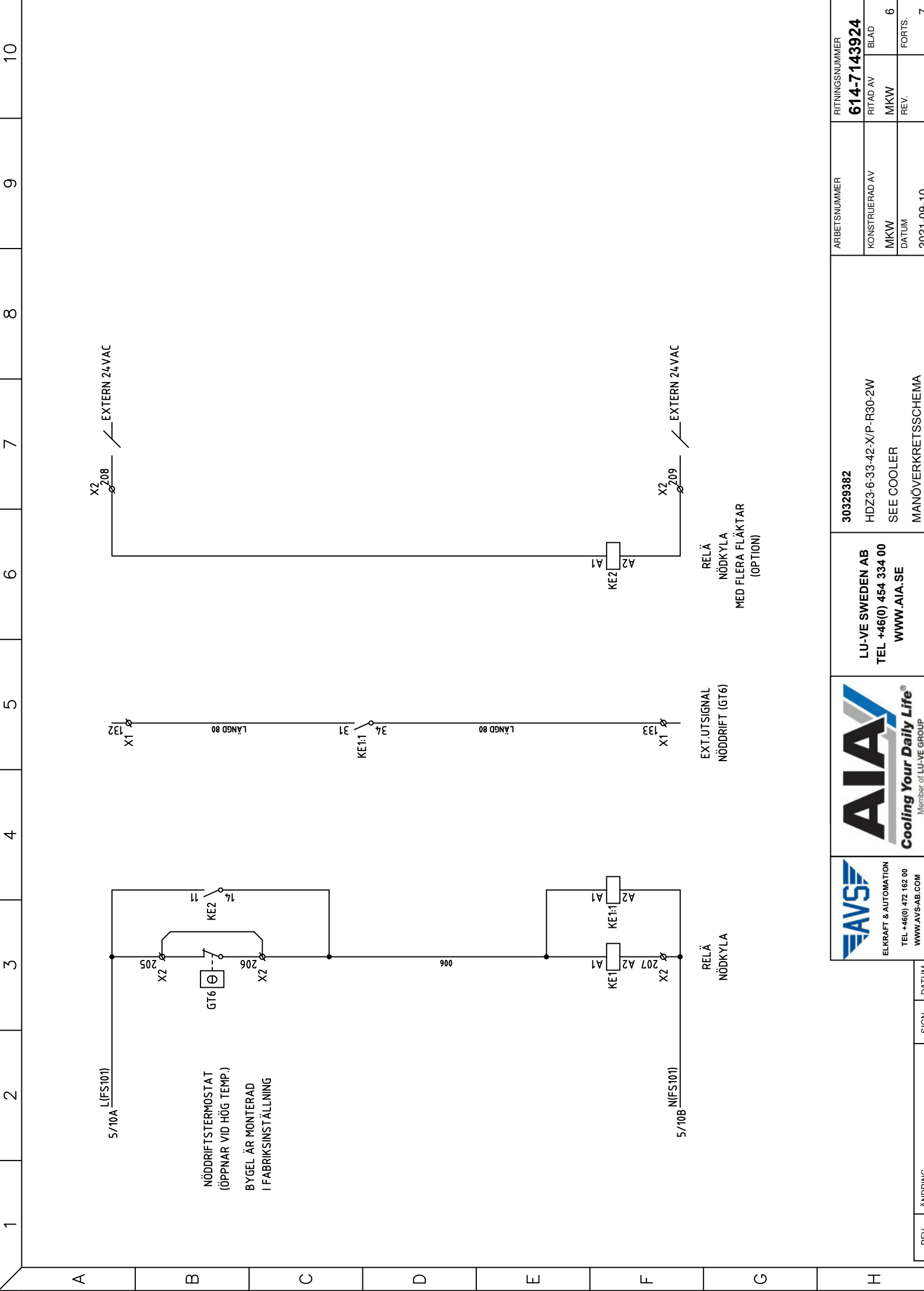

NÖDRIFTSTERMOSTAT  
(ÖPPNAR VID HÖG TEMP.)  
BYGEL ÄR MONTERAD  
I FABRIKSINSTÄLLNING

RELÄ  
NÖDKYLA

EXT.UTSIGNAL  
NÖDRIFT (GT6)

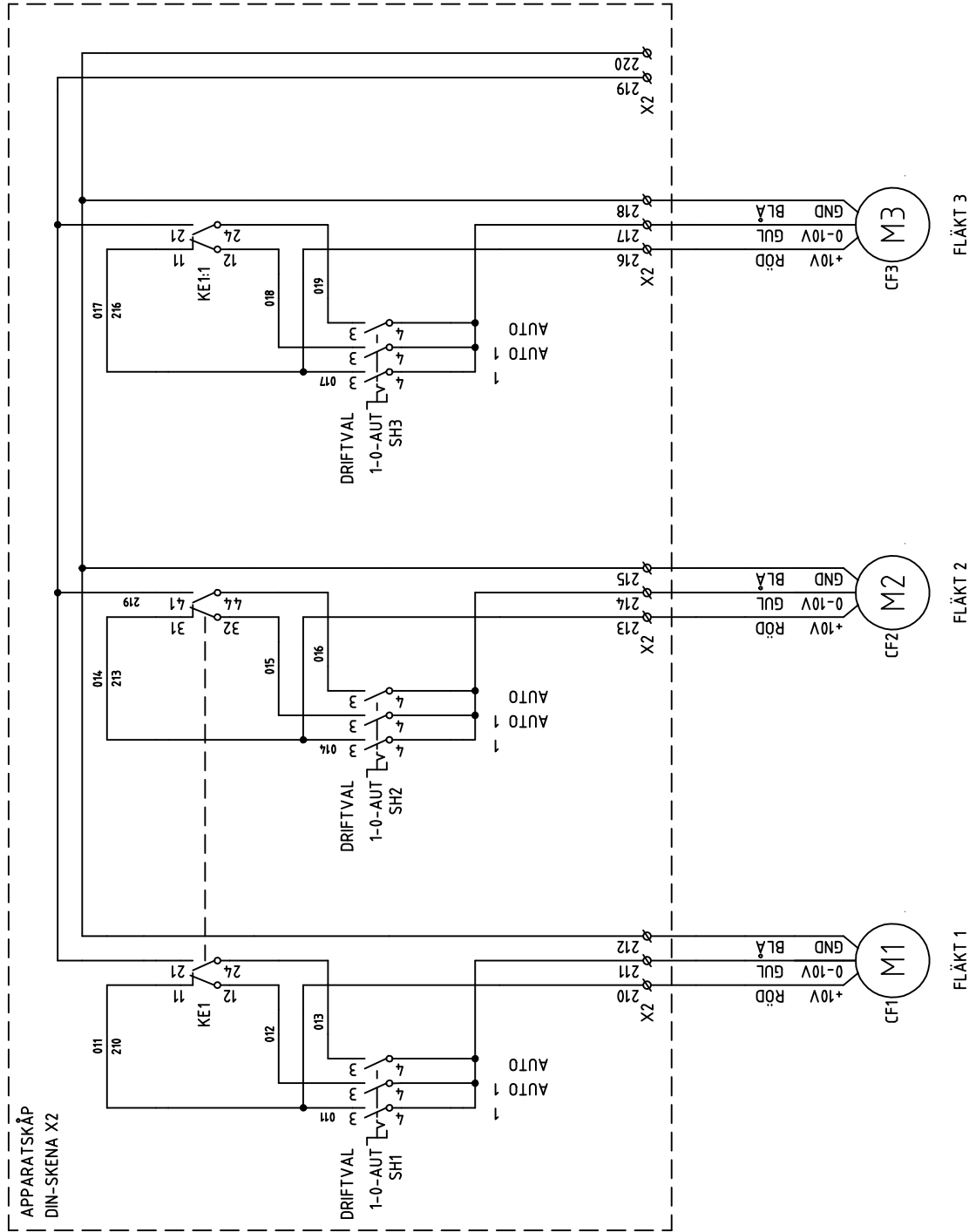

RELÄ  
NÖDKYLA  
MED FLERA FLÄKTAR  
(OPTION)

REV.	ÄNDRING	SIGN.	DATUM	 <p>ELKRAFT &amp; AUTOMATION TEL +46(0) 472 162 00 WWW.AVS-AB.COM</p>	 <p>Cooling Your Daily Life® Member of LU-VE GROUP</p>	<p><b>LU-VE SWEDEN AB</b> TEL +46(0) 454 334 00 <b>WWW.AIA.SE</b></p>	<p><b>30329382</b> HDZ3-6-33-42-X/P-R30-2W SEE COOLER MÄNÖVERKRETSSCHEMA</p>	ARBETSNUMMER	<p><b>614-7143924</b> RITAD AV MKW REV. 2021-09-10</p>	RITINGSNUMMER	<p>BLAD 6 FORTS. 7</p>		
								KONSTRUERAD AV					
								MKW					
								DATUM					



APPARATSKÅP  
DIN-SKENA X2

REV.	ÄNDRING	SIGN.	DATUM
<p>ELKRAFT &amp; AUTOMATION TEL +46(0) 472 162 00 WWW.AVS-AB.COM</p>			
<p><b>AIA</b> Cooling Your Daily Life Member of LU-VE GROUP</p>			
<p>LU-VE SWEDEN AB TEL +46(0) 454 334 00 WWW.AIA.SE</p>			
<p>30329382 HDZ3-6-33-42-X/P-R30-2W SEE COOLER MÄNÖVERKRETSSCHEMA</p>			
ARBETSNUMMER	RITTINGSNUMMER		
KONSTRUERAD AV	614-7143924		
MKW	BLAD	REV.	FORTS.
MKW	MKW	7	8
DATUM	2021-09-10		

1	2	3	4	5	6	7	8	9	10																																								
A	<p>HUVUDBRYTARE MAX LAST 40A</p> <p>X1</p> <p>QD1</p> <table border="0"> <tr><td>L1</td><td>2</td><td>1</td></tr> <tr><td>ANSLUTES DIREKT PÅ</td><td>4</td><td>3</td></tr> <tr><td>HUVUDBRYTARE</td><td>6</td><td>5</td></tr> <tr><td>3X400VAC ALT. 1X230VAC<sup>N</sup></td><td>8</td><td>7</td></tr> <tr><td>PE</td><td></td><td></td></tr> </table>									L1	2	1	ANSLUTES DIREKT PÅ	4	3	HUVUDBRYTARE	6	5	3X400VAC ALT. 1X230VAC <sup>N</sup>	8	7	PE																											
L1	2	1																																															
ANSLUTES DIREKT PÅ	4	3																																															
HUVUDBRYTARE	6	5																																															
3X400VAC ALT. 1X230VAC <sup>N</sup>	8	7																																															
PE																																																	
B	-----																																																
C	<p>HUVUDBRYTARE MAX LAST 40A</p> <p>X2</p> <p>QD2</p> <table border="0"> <tr><td>L1</td><td>2</td><td>1</td></tr> <tr><td>ANSLUTES DIREKT PÅ</td><td>4</td><td>3</td></tr> <tr><td>HUVUDBRYTARE</td><td>6</td><td>5</td></tr> <tr><td>3X400VAC ALT. 1X230VAC<sup>N</sup></td><td>8</td><td>7</td></tr> <tr><td>PE</td><td></td><td></td></tr> </table>									L1	2	1	ANSLUTES DIREKT PÅ	4	3	HUVUDBRYTARE	6	5	3X400VAC ALT. 1X230VAC <sup>N</sup>	8	7	PE																											
L1	2	1																																															
ANSLUTES DIREKT PÅ	4	3																																															
HUVUDBRYTARE	6	5																																															
3X400VAC ALT. 1X230VAC <sup>N</sup>	8	7																																															
PE																																																	
D	-----																																																
E	<p>HUVUDBRYTARE MAX LAST 40A</p> <p>X3</p> <p>QD3</p> <table border="0"> <tr><td>L1</td><td>2</td><td>1</td></tr> <tr><td>ANSLUTES DIREKT PÅ</td><td>4</td><td>3</td></tr> <tr><td>HUVUDBRYTARE</td><td>6</td><td>5</td></tr> <tr><td>3X400VAC ALT. 1X230VAC<sup>N</sup></td><td>8</td><td>7</td></tr> <tr><td>PE</td><td></td><td></td></tr> </table>									L1	2	1	ANSLUTES DIREKT PÅ	4	3	HUVUDBRYTARE	6	5	3X400VAC ALT. 1X230VAC <sup>N</sup>	8	7	PE																											
L1	2	1																																															
ANSLUTES DIREKT PÅ	4	3																																															
HUVUDBRYTARE	6	5																																															
3X400VAC ALT. 1X230VAC <sup>N</sup>	8	7																																															
PE																																																	
F	-----																																																
G	-----																																																
H	<table border="0"> <tr> <td>AVS</td> <td>ELKRAFT &amp; AUTOMATION</td> <td>TEL +46(0) 472 162 00</td> <td>WWW.AVS-AB.COM</td> </tr> <tr> <td colspan="4" style="text-align: center;">    <b>AIA</b>                  Cooling Your Daily Life®                  Member of LU-VE GROUP             </td> </tr> <tr> <td colspan="4" style="text-align: center;">                 LU-VE SWEDEN AB                  TEL +46(0) 454 334 00                  WWW.AIA.SE             </td> </tr> <tr> <td colspan="4" style="text-align: center;">                 30329382                  HDZ3-6-33-42-X/P-R30-2W                  SEE COOLER                  YTTRE ANSLUTNINGSSCHEMA             </td> </tr> <tr> <td>ARBETSNUMMER</td> <td colspan="3">30329382</td> </tr> <tr> <td>KONSTRUERAD AV</td> <td colspan="3">MKW</td> </tr> <tr> <td>DATUM</td> <td colspan="3">2021-09-10</td> </tr> <tr> <td>RITINGSNUMMER</td> <td>614-7143924</td> <td>BLAD</td> <td>8</td> </tr> <tr> <td>REV.</td> <td>ÄNDRING</td> <td>SIGN.</td> <td>DATUM</td> </tr> <tr> <td></td> <td></td> <td></td> <td></td> </tr> </table>									AVS	ELKRAFT & AUTOMATION	TEL +46(0) 472 162 00	WWW.AVS-AB.COM	 <b>AIA</b> Cooling Your Daily Life® Member of LU-VE GROUP				LU-VE SWEDEN AB TEL +46(0) 454 334 00 WWW.AIA.SE				30329382 HDZ3-6-33-42-X/P-R30-2W SEE COOLER YTTRE ANSLUTNINGSSCHEMA				ARBETSNUMMER	30329382			KONSTRUERAD AV	MKW			DATUM	2021-09-10			RITINGSNUMMER	614-7143924	BLAD	8	REV.	ÄNDRING	SIGN.	DATUM				
AVS	ELKRAFT & AUTOMATION	TEL +46(0) 472 162 00	WWW.AVS-AB.COM																																														
 <b>AIA</b> Cooling Your Daily Life® Member of LU-VE GROUP																																																	
LU-VE SWEDEN AB TEL +46(0) 454 334 00 WWW.AIA.SE																																																	
30329382 HDZ3-6-33-42-X/P-R30-2W SEE COOLER YTTRE ANSLUTNINGSSCHEMA																																																	
ARBETSNUMMER	30329382																																																
KONSTRUERAD AV	MKW																																																
DATUM	2021-09-10																																																
RITINGSNUMMER	614-7143924	BLAD	8																																														
REV.	ÄNDRING	SIGN.	DATUM																																														



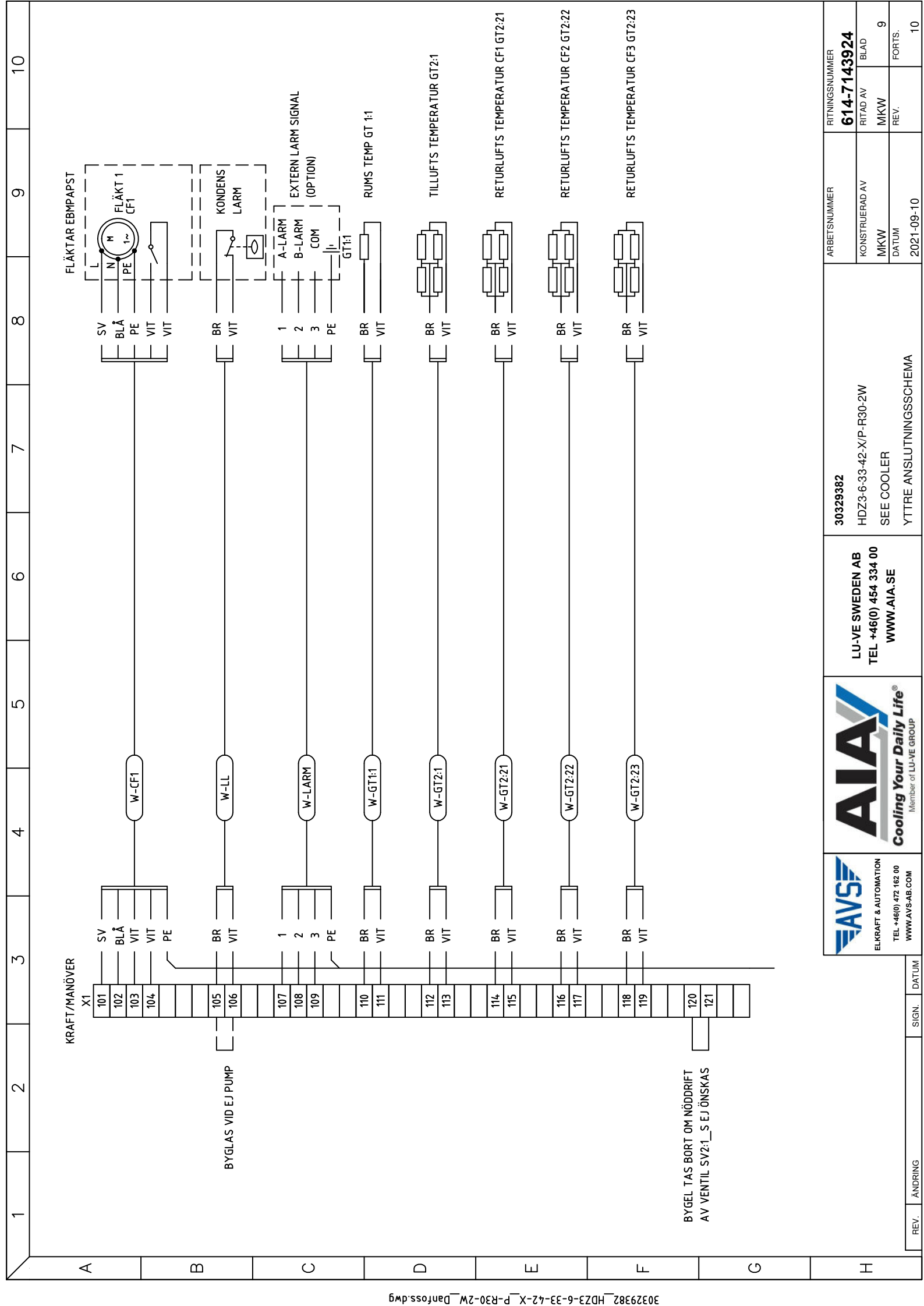

REV.	ÄNDRING	SIGN.	DATUM
------	---------	-------	-------

ELKRAFT & AUTOMATION  
TEL +46(0) 472 162 00  
WWW.AVS-AB.COM

**AIA**  
Cooling Your Daily Life®  
Member of LU-VE GROUP



**LU-VE SWEDEN AB**  
TEL +46(0) 454 334 00  
WWW.AIA.SE

**30329382**  
HDZ3-6-33-42-X/P-R30-2W  
SEE COOLER  
YTTRE ANSLUTNINGSSCHEMA

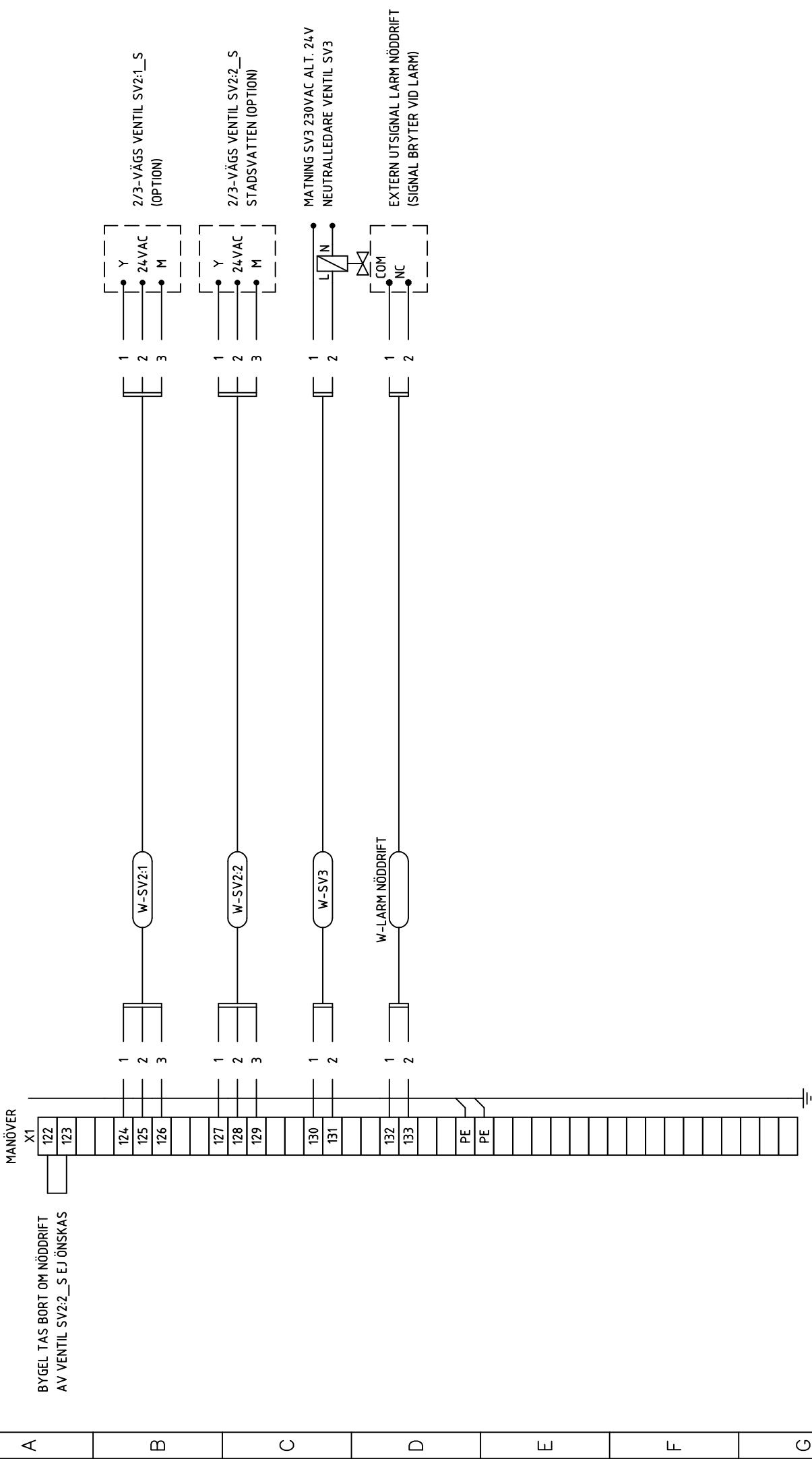
ARBETSNUMMER	RITINGSNUMMER
KONSTRUERAD AV	<b>614-7143924</b>
MKW	RITAD AV
MKW	BLAD
REV.	9
DATUM	FORTS.
2021-09-10	10



1	2	3	4	5	6	7	8	9	10
---	---	---	---	---	---	---	---	---	----

 ELKRAFT & AUTOMATION TEL +46(0) 472 162 00 WWW.AVS-AB.COM	 Cooling Your Daily Life® Member of LU-VE GROUP	<b>LU-VE SWEDEN AB</b> TEL +46(0) 454 334 00 <b>WWW.AIA.SE</b>	<b>30329382</b> HDZ3-6-33-42-X/P-R30-2W SEE COOLER YTTRE ANSLUTNINGSSCHEMA	ARBETSNUMMER	RITTINGSNUMMER
				KONSTRUERAD AV	RITAD AV
		MKW	MKW	REV.	BLAD
		DATUM	DATUM		FORTS.
			2021-09-10		11

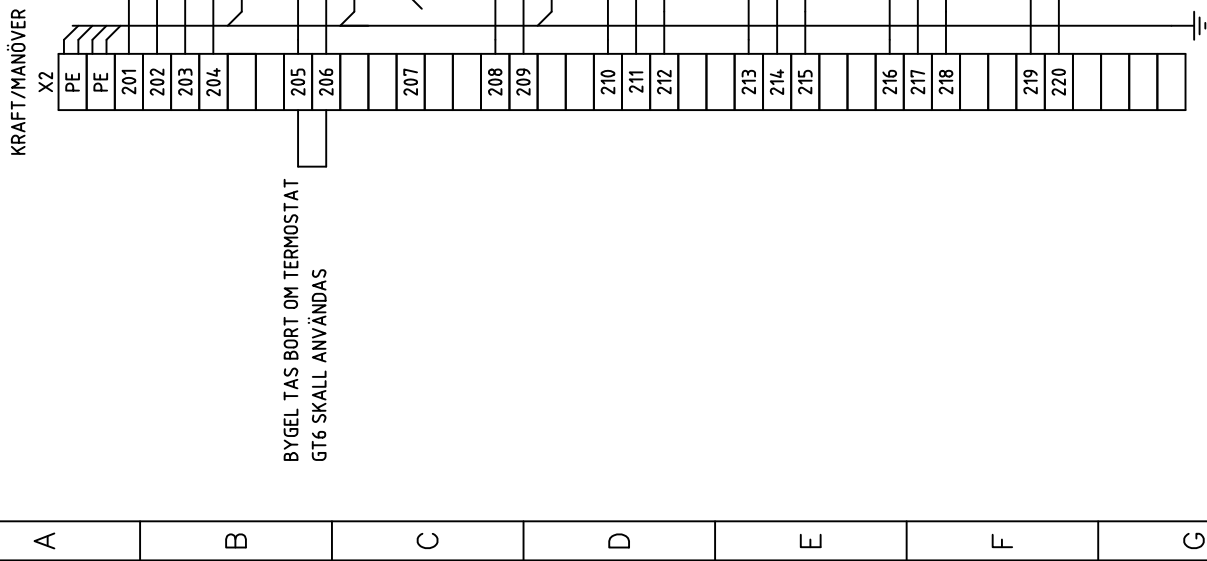

KRAFT/MÄNÖVER  
X2

BYGEL TAS BORT OM TERMOSTAT  
GT6 SKALL ANVÄNDAS

Se blad 6

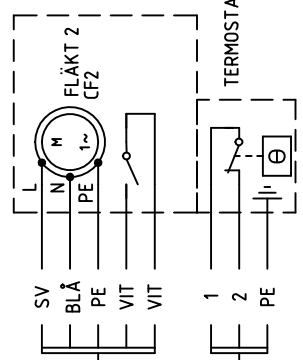

EXTERN 24VAC NÖDRIFT  
ANVÄNDS VID FLERA FLÄKTAR

FLÄKT 1

FLÄKT 2

FLÄKT 3

STYR SIGNAL 0-10VOLT FRÅN KR1  
(X1)

1 2 3 4 5 6 7 8 9 10

A B C D E F G H



**LU-VE SWEDEN AB**  
TEL +46(0) 454 334 00  
**WWW.AIA.SE**

**30329382**  
HDZ3-6-33-42-X/P-R30-2W  
SEE COOLER  
YTTRRE ANSLUTNINGSSCHEMA

ARBETSNUMMER	RITTINGSNUMMER
KONSTRUERAD AV	<b>614-7143924</b>
MKW	BLAD
DATUM	MKW
2021-09-10	REV.
	11
	FORTS.
	12

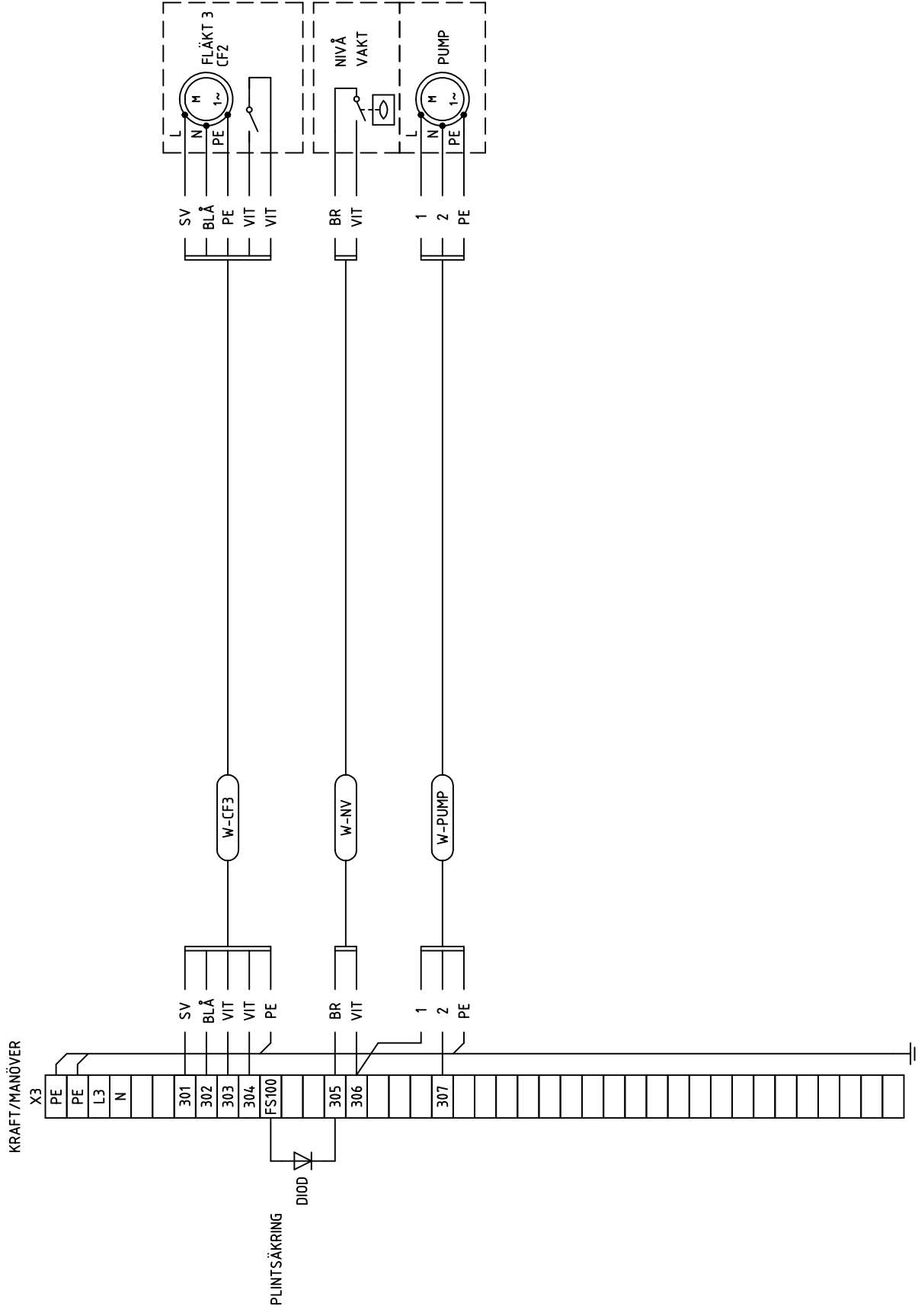

LU-VE SWEDEN AB  
TEL +46(0) 454 334 00  
WWW.AIA.SE

30329382

HDZ3-6-33-42-X/P-R30-2W  
SEE COOLER  
YTTR E ANSLUTNINGSSCHEMA

ARBETSNUMMER	
KONSTRUERAD AV	MKW
DATUM	2021-09-10
REV.	
RITAD AV	MKW
BLAD	12
FORTS.	/

RITINGSNUMMER	614-7143924
---------------	-------------

REV.	ÄNDRING	SIGN.	DATUM
------	---------	-------	-------